

## GLASS RAILING SYSTEMS

# SYSTEM TYPE: OPEN AIR PLUS

### FLOOR ANCHORING



Combining innovative technologies with special design lines, the Open Air System is the ultimate answer to the demand for contemporary and stylish outdoor spaces such as restaurants, cafes, roof gardens, hotels etc.

A unique innovation, patented, where the moving part of the system is raised or lowered with a single motion and effortlessly according to our wishes and weather conditions..



### 1. SYSTEM FEATURES

- **Outstanding Elegance**

Open Air Ultra Plus is equipped with a bottom rail offering extra wind protection, which is sustained by fine mullions. The Open Air system guarantees excellent functionality and safety;



- **Easy to Use**

It is adjustable adaptable and remarkably easy to use. It is distinctly designed to be easy to handle so that the movable part elevates with just a light pressure.;

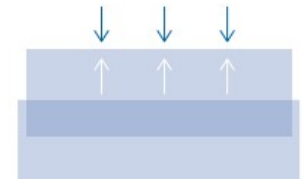

- **Light & Robust**

The frame is made of aluminium profile combined with safety crystal clear glass, tempered glass 4.4.4 PVB at the fixed part and monolithic glass 6mm at the moving part. The glass and the whole structure are designed to be substantially durable and resistant.



- **Unique Open Air Protection**

All models perform extremely well in the outdoor, providing sound insulation and protection from extreme weather conditions.



- **Convenient Installation**

The system is carefully designed to be easily installed within a small amount of time.



TIME SAVING

- **Tested & Approved**

Open Air Systems have been tested and approved by notable Testing Laboratories to meet and exceed quality, safety and performance standards



## 2. TECHNICAL DATA

- Designed for: domestic use and public places;
- Use: outside, also by the sea;
- Variants: floor mounted;
- Applications: balconies and balustrades;
- Material: anodized aluminium;
- Infill: tempered glass 44.4 at the fixed part and monolithic glass 6mm at the moving part;
- Upper finish: available in black anodic or anodic 420;

## 3. CERTIFICATION. TESTS

- Glass EN 12600;
- Intertek;
- Swiss CERT;



## 4. EXTERNAL CORNERS (C-EXT) / INTERNAL CORNERS (C-INT)

All types of the Open air system can be delivered in two standard corners of 90° angle, internal (C-INT) and external (C-EXT)

### External corners (C-EXT) 270°

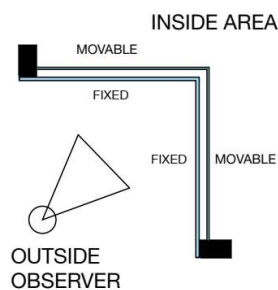

### Internal corners (C-INT) 90°

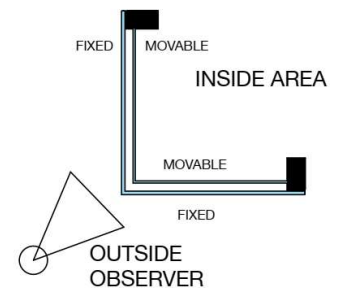

Open air  
PLUS



OPEN AIR PLUS	OA 1800 C-INT/C-EXT	OA 2000 C-INT/C-EXT
<b>Length</b>	500 mm (L)	500 mm (L)
<b>Height</b>	Closed 1100 mm (H1) Opened 1800 mm (H2)	Closed 1200 mm (H1) Opened 2000 mm (H2)
<b>Column dimensions</b>	(50x100) mm	(50x100) mm

## 5. ATTENTION TO DETAIL

### Technology at your fingers!

For proper operation just place your fingers at the points indicated by the easily removable sticker (PUSH HERE) which is placed at the center of the windscreen. Then, with just a single press-release action to the movable part, the windscreen lifts to the upper position.

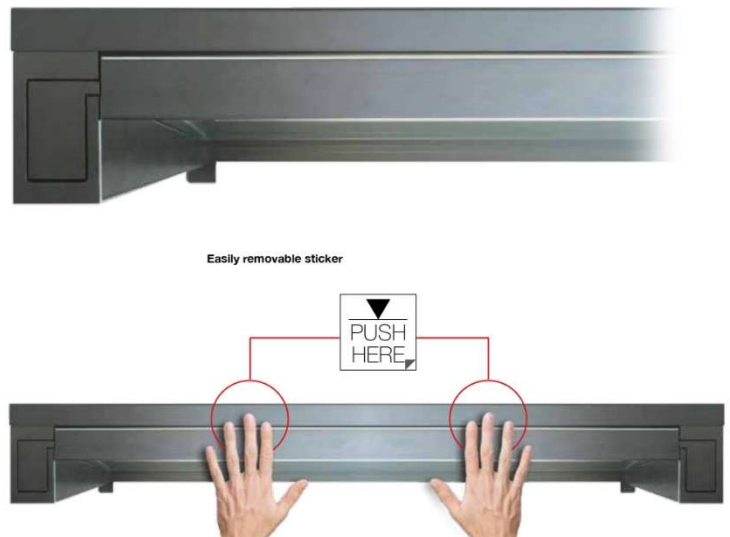

### Durability and wind protection up to 120 Km/h

The powerful shape of Open Air System contributes to enhanced safety and security even in the event of the most extreme wind loads.

Each and every element is a work of precision demanding rare and exacting know-how, tested and approved by notable Testing Laboratories to meet and exceed quality, safety and performance standards..

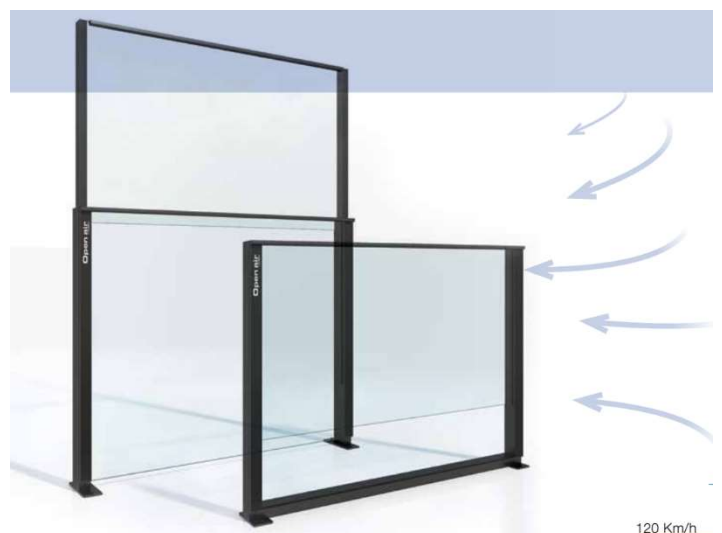

## 6. INSTALLATION

- Drill the holes into the floor where the holes of the post anchor are located by using the most suitable drilling bit;

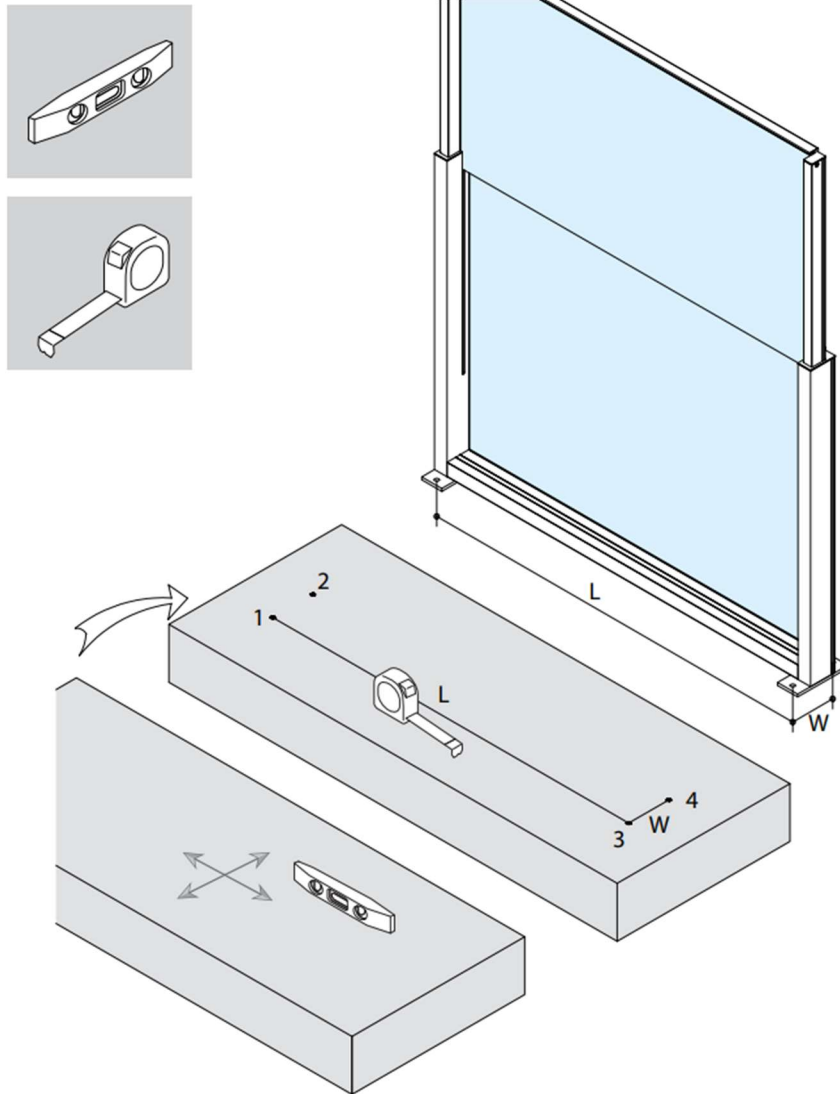

- Use the proper screw anchors for both the surface and type of material of the part where the posts are anchored;

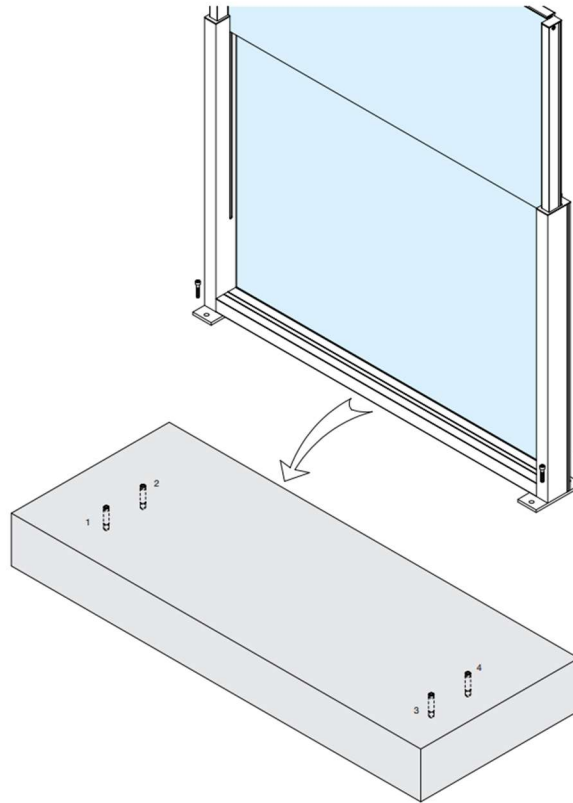

- Anchor on two points;

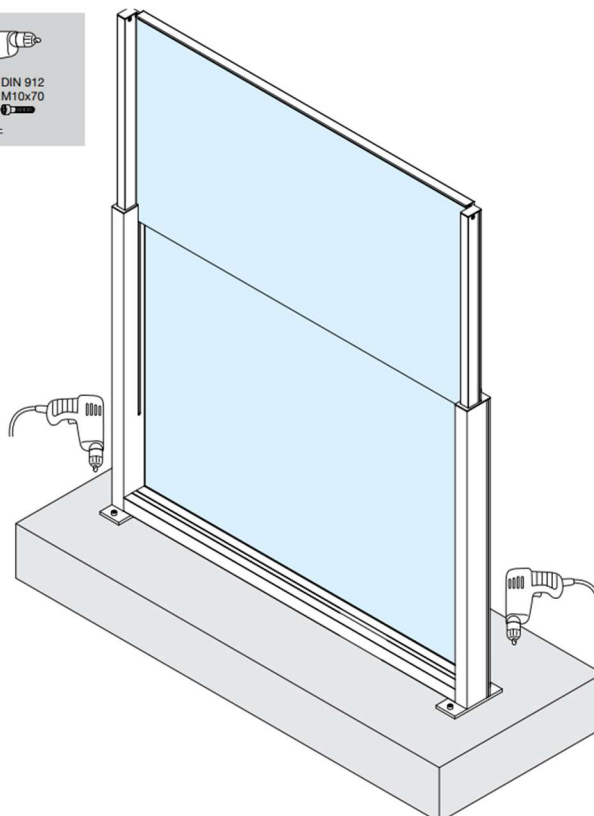
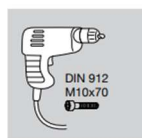

- Ground should be fully aligned

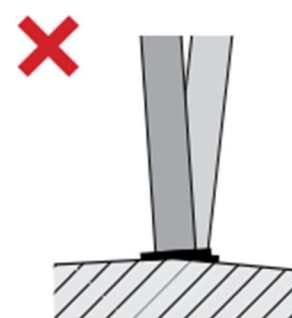
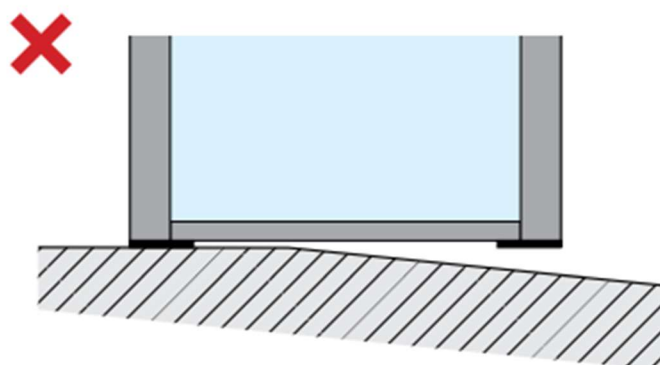
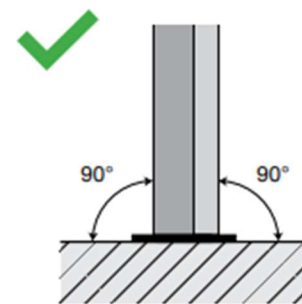
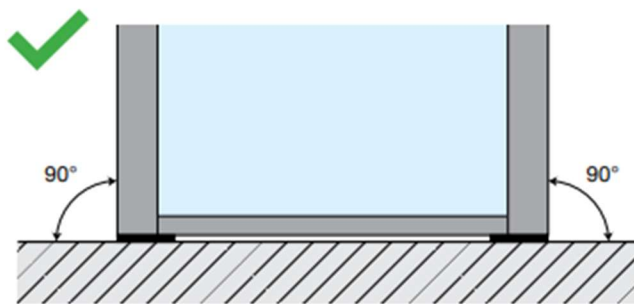
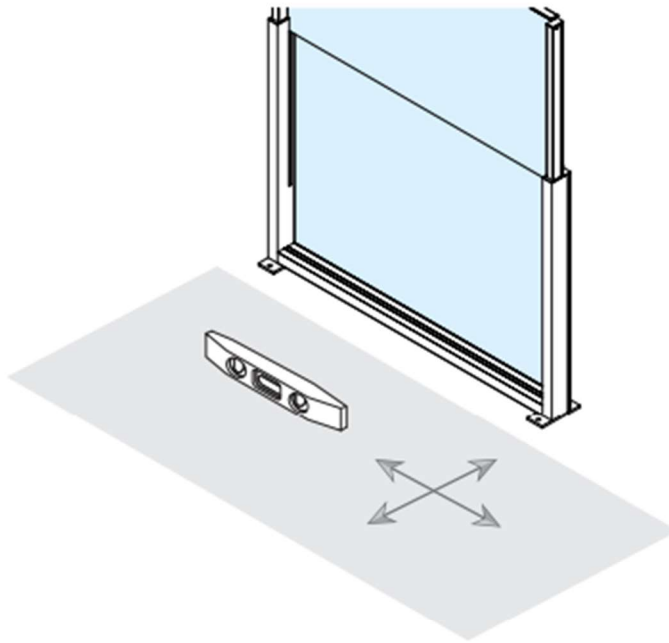



## 7. GLASS

### Tempered glass

Tempering is a heat treating that produces a pre-compression condition on glass surfaces; a reduction of micro blemishes is therefore achieved. After being tempered, glass develops a resistance that is four times higher than a traditional float glass. Another advantage is that, in case of breakage, you will have little fragments without sharp edges.

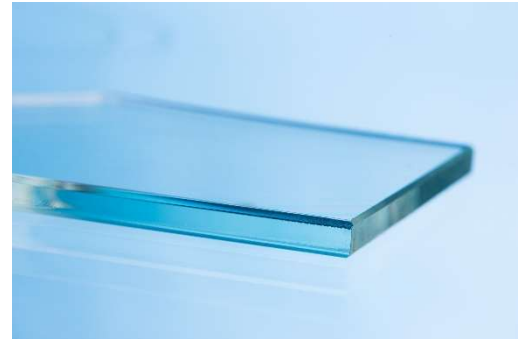

### Laminated glass

By joining two or more tempered glass layers and alternating them with a plastic sheet, we get a composite panel, where, in case of a break, fragments remain cohesive. Plastic materials which are usually in PVB or EVA, are interjected between two or more layers, thanks to specific processes that allow them to reach a composite panel with mechanical, heat and acoustic performances.

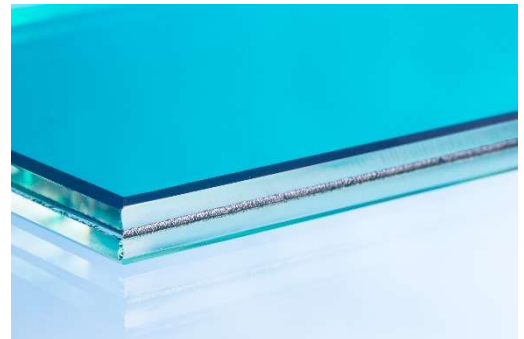

### Advantages of security stratified glass in case of breakage:

- Fragments and splinters pinned by plastic;
- It stands even after break and it can be replaced;
- Decreased fall of dangerous fragments on people;
- Decreased injury risk caused by human impact;
- Increased mechanical resistance to break – through and penetration

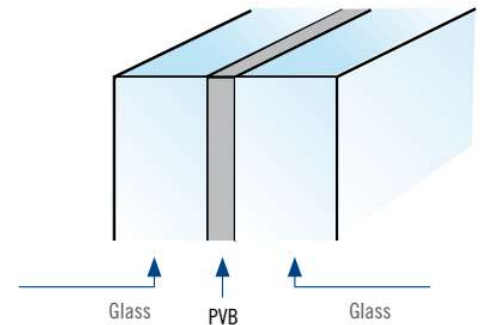
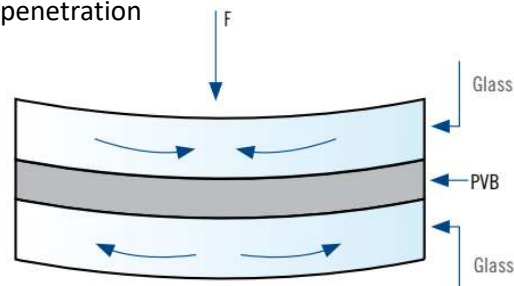

- from 6 mm monolithic toughened glass to 17.52mm (88.4) toughened laminated glass;
- optional coloured or tint glass;
- radius corners and polished edges on request;
- optional drilled holes;

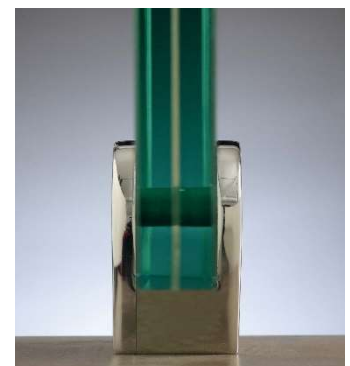



## 8. DRAWINGS



OPEN AIR PLUS	OA 1600	OA 1800	OA 2000
<b>Length</b>	Max 2000 mm (L)	Max 2000 mm (L)	Max 2000 mm (L)
<b>Height</b>	Closed 1000 mm (H1) Opened 1600 mm (H2)	Closed 1100 mm (H1) Opened 1800 mm (H2)	Closed 1200 mm (H1) Opened 2000 mm (H2)
<b>Column dimensions</b>	(50x100) mm	(50x100) mm	(50x100) mm

## 9. EXTRAS

A variety of extras is provided to add value to the Open Air system, such as a wheeled base, extra sealing or additional profiles.

### Trolley base

A base with wheels and a specially designed brake system can be embedded in each part of the Open Air system, so that every part can be moved safely and easily.



### Two open air parts connected as one

A special connecting mechanism is used to connect two open air parts in order to ensure even more safety and stability. The connector is placed vertically on the base and joins two Open Air systems.



### Smart lock

Smart locking options are also provided to offer bigger safety. The safety locks permit to lock the moving part of the system in its highest position while the stopper lock gives the possibility to adjust the height.



## Create your own design

Open air modules provide the option where your professional brand name, logo or any other message can be placed on glasses to maximize your communication.

